

mud

Candy pedals are generally unaffected by mud and other organic matter. In extreme cases, you may need to twist back and forth in order to engage (this will push particularly thick mud through the pedal). Do not use pressurized water on the Candy.

maintenance

Very little maintenance is required with Candy pedals. In normal conditions, the bearings are waterproof and all materials are rust-resistant. There is no need to lubricate the exterior of the pedal. The pedals are generally self-cleaning and in most cases, dried mud and dirt will fall off on their own. However, you should occasionally inspect your pedals for damage, wear, or excessive play.

Cleats: Eventually the cleats will wear out and need to be replaced. Inspect the cleats regularly and look for signs of wear. If you are inadvertently pulling out of the pedals (without twisting), then there is a good chance that the cleats are worn out. Another sign of wear is a feeling that the pedal is sloppy. The cleats are made of a material, which is softer than the pedal body bars. This is on purpose so that the cleats wear rather than the pedal. Cleats generally last about 500 hours of riding, depending on style of riding, and riding conditions.

re-greasing overview:

Candy pedals can be easily re-greased using the grease adapter (included with most models, or available from Crank Brothers) and a grease gun. For maximum durability (and depending on your riding conditions), you should re-grease your pedals after every 100 to 300 hours of riding. Wet or muddy conditions are the most severe. Re-greasing will flush out the old grease and any contamination. Re-greasing only takes a few minutes per pedal and can be done with the pedal still on the crank arms. Use any high quality bicycle grease available at bicycle stores.

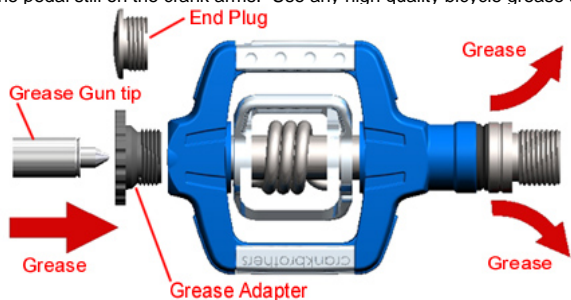

-5-

re-greasing instructions:

1. Lay your bike down on its side.
2. Remove the End Plug using a flat bladed screw driver.
3. Screw the Grease Adapter into the end of the pedal. Tighten with fingers to seal.
4. Push the tip of the grease gun firmly into the center of the grease adapter and activate grease gun. Grease will begin coming out of the spindle end of the pedal body. When the grease appears to be fresh, the pedal is re-greased. Wipe excess grease away from pedal.
5. Remove the grease adapter and screw back in the End Plug.

warranty

Crank Brothers pedals are warranted against defects in workmanship for 2 years (twice most others) from the date of purchase. Your receipt will be required as proof of any warranty claims. Contact Crank Brothers directly for warranty at 949-464-9916 or info@crankbrothers.com. This warranty is limited to the repair or replacement of this product. Crank Brothers at its option will either repair or replace any defective parts. This warranty does not cover damage caused by rider errors. However, we at Crank Brothers are reasonable people and we believe in our product, so if you can give us a reasonable explanation, we'll fix or replace even your rider error damaged pedals.

caution: please read this before you ride

- Before riding, study carefully how the locking mechanism of the Candy works. Place one foot on smooth level ground and practice engaging and disengaging from each pedal numerous times.
- Even if you are experienced with clipless pedals, all clipless pedals take some practice. Get used to them before riding.
- Clipless pedals require special bicycle shoes. The Candy Cleats are compatible with all standard SPD® shoes. In rare instances, you may need to shave the tread in selected areas (or use the provided shims) in order to work properly with the Candy. Note: Candy Cleats are compatible with all Crank Brothers pedals.
- Use only Crank Brothers cleats with Candy pedals.
- Inspect the cleats regularly and replace them when they are worn out.
- If the cleats are not installed correctly, you could experience knee damage. Note that some people's legs are not symmetric so be sure that both cleats are adjusted correctly for your body. We suggest you consult your local bike shop for a pedal fit specialist.
- The Candy pedal is so low profile compared to most other pedals that you may need to lower your seat slightly.

For more information regarding the mounting of the pedals, their use, or maintenance, please go to your authorized dealer or contact Crank Brothers. Always use a helmet and follow the rules of the road when cycling. Always use proper headlights and taillights when riding at times of reduced visibility.

-6-

re-building overview:

If the pedal becomes loose or feels gritty when it turns, then the pedal needs to be rebuilt. Crank Brothers can rebuild your pedals for you, or you can rebuild them yourself using a rebuild kit available from your local retailer or Crank Brothers (www.crankbrothers.com). It is relatively easy to replace the bushing and cartridge ball bearing. The typical tools required are a 6mm or 8mm Hex, flat head screw drivers, and an 8mm socket and driver. You'll also need some grease and a rag. Applying the grease is easiest and most thorough if you use a grease gun, but it can be done manually, too. For more information, please contact your local retailer or Crank Brothers. **Do not try to disassemble the Body Assembly because special tools are required for re-assembly.**

disassembly

step 1 • Remove End Plug

Remove the End Plug with a wide flat bladed screwdriver.

step 2 • Remove Nut

Remove and discard the Nut using an 8mm socket and a 6mm or 8mm hex on the Spindle.

step 3 • Remove Spindle

Pull the Spindle out of the Body Assembly and place on a clean rag.

step 4 • Remove Cartridge Ball Bearing

Remove and discard cartridge ball bearing. If it does not fall out, then push out from other end using a 6mm hex or similar object.

step 5 • Remove Seals

Remove and discard the inner and outer seals. Note: the inner seal has an internal steel reinforcement so that it press fits into the Body of the pedal. You may need to wedge out the seal with a small flat bladed screwdriver.

step 6 • Remove Bushing

Remove and discard Bushing, using screwdriver. It may be necessary to dig the screwdriver into the Bushing to remove it. If the Bushing is difficult to remove, try pulling the Bushing out by digging the head of a nail under the back of the Bushing. Pull on the nail using a pliers. If this still doesn't work, as a last resort, you can break the Bushing if you push a small flat bladed screw driver between the outside of the Bushing and the inside of the pedal Body (wear safety glasses), as shown in the above picture. Try not to scratch the pedal housing.

step 7 • Clean Parts

Using a cloth rag or paper towel, wipe the grease out of the interior of the Body Assembly, the entire End Plug (if it is to be reused), and the outside of the Spindle.



-7-

reassembly

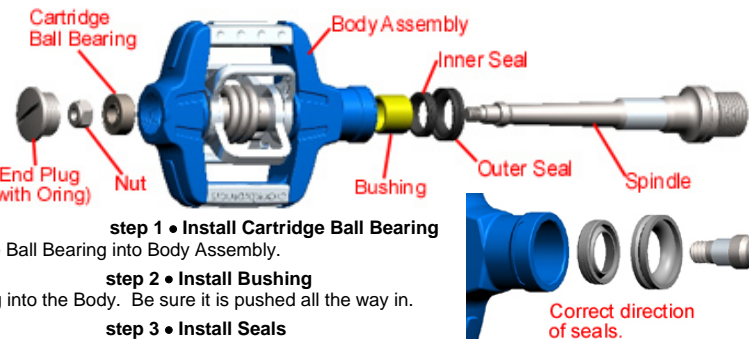

step 1 • Install Cartridge Ball Bearing

Push new cartridge Ball Bearing into Body Assembly.

step 2 • Install Bushing

Install new Bushing into the Body. Be sure it is pushed all the way in.

step 3 • Install Seals

Install inner Seal into Body so that the small rubber lip is facing outwards. Install outer seal on Spindle.

step 4 • Apply Grease

Option 1: Apply grease to all surfaces of the Spindle that will be contained within the Body Assembly except threaded end. Option 2: If you have a grease gun and the Candy grease port adapter, then you can apply the grease after the pedal is assembled per page 6 of these instructions.

step 5 • Install Spindle

Push Spindle into the Body Assembly, being careful that the Seal doesn't get pinched or the sealing lip inverted.

step 6 • Install Nut

Install Nut using a 8mm socket and a 6 or 8mm Hex in the Spindle. Tighten firmly to 30in/lb (3.5NM). **WARNING: The Nut must be tightened correctly or the Body Assembly could fall off during riding and cause injury.**

step 7 • Install End Plug

Install End Plug with a wide flat bladed screw driver. Be sure the O-ring on the End Plug does not get pinched on the pedal Body.



Questions or problems? Visit www.crankbrothers.com

Ph: 949-464-9916 Fax: 949-376-7010 Email: info@crankbrothers.com

Rev A

-8-

features

Candy pedals are the world's first 2-sided pedals with 4-sided entry. The design allows you to clip in, in a variety of ways not possible with other pedals. Additionally, Candy pedals are very light, extremely mud resistant, durable, have 6 degrees of rotational float, and are easily rebuilt.



pedal installation

Candy pedals have a 6 or 8mm Hex on the end of the spindles. Note that the right pedal has a standard right-handed thread and the left pedal has a left-handed thread. For identification, **left pedal has a small groove around the spindle flange.** The right pedal has no special markings.

Grease the threads and then tighten the pedals to 25 to 30 foot pounds torque (34 to 41Nm) with a 6 or 8mm Hex.

cleat installation and adjustment

Candy cleats are compatible with all standard SPD® compatible shoes and do not have a front and back but there is a left and a right cleat that changes the release angle. **Cleats for road shoes are also available.**

Cleat with **the two circles on your right shoe** means **earlier** (15°) **release angle** on both feet.

Cleat with **the two circles on your left shoe** means **later** (20°) **release angle** on both feet.



Cleat with 2 circles



Cleat without circles

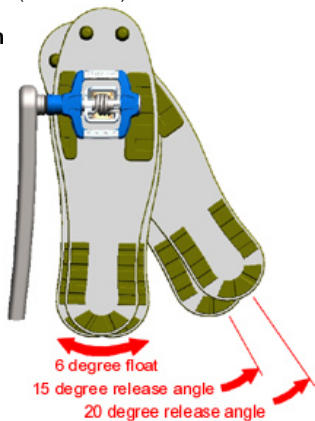

Candy Rev A -1-

Cleat release explanation: When the cleat with the two circles is on your right shoe, it releases at about 15 degrees when your heel is twisted outward, and about 20 degrees when your heel is twisted inward. The cleat without the circles is a mirror image of this. On your right shoe, it releases at about 20 degrees when your heel is twisted outward, and about 15 degrees when your heel is twisted inward. The cleats are symmetric to each other. Therefore, **both your feet will release the same** (early or late) as each other.

We recommend beginners always start with the cleat with the two circles on the right shoe. Many experienced riders prefer this position as well.

Step One: Position the cleat on the shoe and install 4mm Hex screws through the cleat and into the metal plate in your shoe. Tighten the screws securely (40-50 in-lb (4-5 Nm)). Note: the cleats can rotate a few degrees each direction in order to allow you to customize the right position for you. You will probably need to reposition the cleats a few times in order to place them in the best position.

Note: There are 4 long and 4 short cleat screws. Use the length that best fits your shoe, being sure that you have at least 3 full turns to tighten the screw.

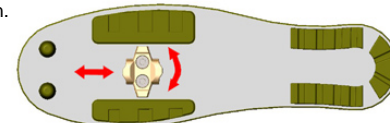

Step Two: Place one foot on smooth level ground and engage your other shoe into the pedal. Rotate your foot back and forth a few times to feel the free float. For most people, the best position for the cleat allows you to pedal comfortably without having to twist against the spring tension. In other words, when the cleat is properly positioned, you will feel a few degrees of rotational motion without feeling spring tension. Twist your heel outward to disengage from the pedal.

Step Three. If the cleat is not in the correct position, loosen both screws and twist the cleat slightly. Re-tighten the screws securely and repeat Step Two.

spring tension

With conventional pedals, if the spring tension is set low, then it is easy to unclip but also easy to accidentally pull out of the pedal. If the spring tension is set high, then it is very hard to clip in or out.

The unique patented Candy design eliminates the need for spring tension adjustment. Retention is not dependent on spring tension. Clipping in and out will become easier after the cleats break in.

engaging the pedals

The Candy gives you entry options that no other pedal can. With any of these options, you will need to put enough force to spread open the pedal. There will be an audible "click" sound when the pedal is engaged. To verify you are engaged, pull slightly upwards.

engage option 1:

Step down and forwards into the pedal.

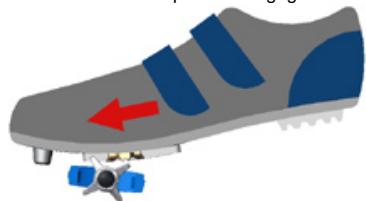

engage option 2:

Step down with the cleat behind the pedal. Then shimmy forwards and the pedal bars will flip over and engage.



Pedal bars will flip over and engage.

engage option 3:

Step down with the cleat in front of the pedal. Then pull backwards and the pedal bars will flip over and engage. Usually it is easiest to make the pedal bars flip over to engage during the downward stroke while pedaling.



Pedal bars will flip over and engage.

These techniques take some practice. Place one foot on smooth level ground and practice engaging and disengaging from each pedal a number of times. Even if you are experienced with clipless pedals, all clipless pedals take some practice to get used to. Get used to them before going off-road or anywhere dangerous.

candy instructions

disengaging from the pedals

Release from the pedal is achieved by an outward twist of the heel. It is also possible to release by twisting inwards but generally this only takes place accidentally. When you want to disengage, most riders find it easiest and safest to do so by twisting outward. If you prefer twisting inwards, we recommend you place the cleat with two circles on your left shoe.

tread interference (difficult clip in and out)

Some shoes have a tread that is higher than average, which can cause interference with the pedal, making it difficult to clip in and out of the Candy pedals. If you have tread interference, the shims should help. Ideally, the tread of your shoe contacts the pedal, but not too much. With ideal contact, you will achieve maximum stability with easy clip in and out.

Try to clip your shoes in the pedals when you're not wearing them and look closely to see if it appears there is excessive contact between the tread and the pedal. If the pedal compresses the tread, then you have interference that will make clipping in and out more difficult. If this is the case, then you'll need to either use the Shims provided, or trim your tread. If you decide to trim the tread, we suggest you use a hand-held sanding wheel (like a "Dremel") or a sharp knife, but please be careful (including safety glasses) and remove only a small amount of tread at a time in order to check for interference. In the rare event that you need two Shims per shoe, contact Crank Brothers and we will provide them for free. If you have interference, remove the cleat and place the Shim (with the textured points) towards the shoe and under the cleat. Note: if you use shims, it is more likely that you should use the longer cleat screws.

Do not use the Shim unless you have tread interference or your shoe will be less stable on the pedal. Many shoes will not cause tread interference with Candy pedals.

Also, make sure that you have the cleat with 2 circles on it on your right shoe because this will make both feet release earlier outwards.

