



Service Information

Revised information for carbon steerers

This is a revision to previous service information

This revised bulletin is being released in response to questions from dealers about the proper stem configuration for a Bontrager carbon steerer. Because we cannot test every known stem, and there might be stems out there that we do not know about, **Trek only recommends using a Bontrager stem on any Bontrager, Trek, or Fisher fork with a carbon steerer.** Using any other brand of stem could cause damage and will void the warranty of the fork.

⚠ WARNING! An incorrect stem on a carbon steerer can cause damage to the steerer. A steerer with damage could break suddenly, causing a crash resulting in injury or death. Only Bontrager stems are approved for use on a Bontrager fork with a carbon steerer.

Modern bicycles use high-tech materials and designs that rely on correct maintenance, precision workmanship, and compatibility of the parts. Mechanics must continue to learn the new procedures and requirements of these new bicycles. Incorrect mechanical work on a bicycle could lead to damage or breakage of a part, which could lead to a crash.

This bulletin includes information from an August 2009 Bontrager service bulletin, the Trek and Fisher bicycle owner's manuals, 2010 Madone and Cronus assembly manuals, and new information.

Below the stem

Always place at least one 5mm spacer below the stem. This spacer is **in addition to** the bearing cover (Figure 1), which must be at least 5mm. If the stem rests against the bearing cover, a point load is created on the steerer that could eventually cause the steerer to break.

Above the stem on carbon fiber steerers

With a carbon steerer, always place at least one 5mm spacer above the stem (Figure 2). A stem placed right at the top of the steerer can put too much force on the unsupported cut edge of the steerer, possibly crushing the steerer.

Check headset bearing preload

The bicycle owner's manual tells a rider to check the bearing adjustment of the headset each month. With a carbon steerer, a rider should check more frequently. In addition to the checks in the owner's manual, we recommend an additional quick check: the rider should check to make sure that the spacer(s) below the stem cannot be rotated with the fingers.

Tightening clamp bolts

When tightening clamp bolts on a carbon steerer or other carbon part, make sure to locate proper torque on the part or in the part's manual and set the torque wrench correctly. Gradually tighten each steerer clamp bolt, alternating back and forth in small increments, until both bolts are at the correct torque. Use a similar method wherever there are multiple clamp bolts. Do not tighten one all the way before tightening the other, and do not leave the bolts with unequal torque. With a Bontrager carbon steerer, never tighten the stem bolts clamp bolts to more than 55 lb•in (6 Nm).

Continued

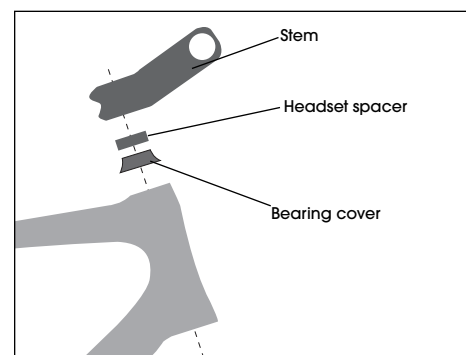

Figure 1. Names of headset parts and spacers (not all parts shown)

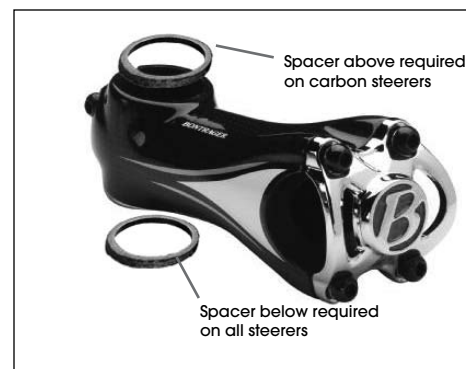

Figure 2. Minimum spacers with a direct connect-type stem

Compatibility with all steerers

Make sure the stem clamp is designed correctly and is free of burrs. Correct design requires that the clamp is circumferential (closes in a circle); never use a wedge-type clamp. Also make sure the clamp bolts are tangential to the steerer (Figure 3). Angled clamp bolts can cause a point load along the clamp.

Clamp edges should be smooth and slightly rounded. If a stem has a sharp or burred edge, sliding it onto the steerer could scratch or cut the carbon fibers, which can weaken the steerer..

Compatibility with carbon steerers

With a carbon steerer, do not use a star-fangled nut; use only the compression nut assembly supplied with the fork. A star-fangled nut can scratch or cut carbon fibers, which can weaken the steerer.

With a carbon steerer, never use a stem with cutaways or holes in the back of the steerer clamp (Figure 4) because this type of clamp can cause uneven pressure on the steerer. Uneven pressure, also called a point load, can damage the steerer. For contrast, the stem in Figure 5 does not have a cutaway.

With a carbon steerer, never use a stem with clamp bolts that require more than 55 lb•in (6 Nm) torque. Excessive torque can crush a carbon steerer.

Use a stem with a carbon-friendly design. The steerer clamp should have the maximum possible surface area and apply even pressure (it should not cause a point load). One cause of point loading is a cutaway in the stem, either in the back as mentioned above, or in a misplaced "lightening hole" (Figure 5). If the lightening hole is too close to the top or bottom of the stem, the narrow, remaining clamp area can cause a point load. To distribute the pressure evenly, the lightening hole should be at least 10mm from the top or the bottom of the stem. If a misplaced lightening hole is combined with incorrect spacers, the stem can crush the steerer.

FSA stems are **NOT** approved for use with Trek carbon-steerer forks.

If you have questions or require additional information

Please contact the Bontrager technical department at 800.879.8735, extension 11804.

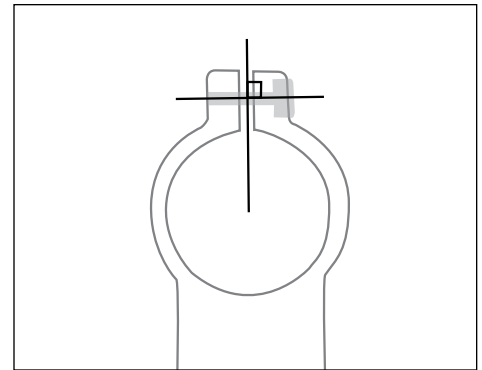

Figure 3. Clamp bolts should be tangential (perpendicular to the radius)



Figure 4. Stem clamp design with point-load

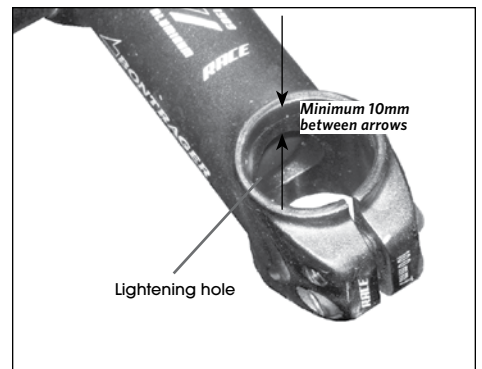

Figure 5. Stem lightening hole